

ARTECH

GX480 CDMA Gateway

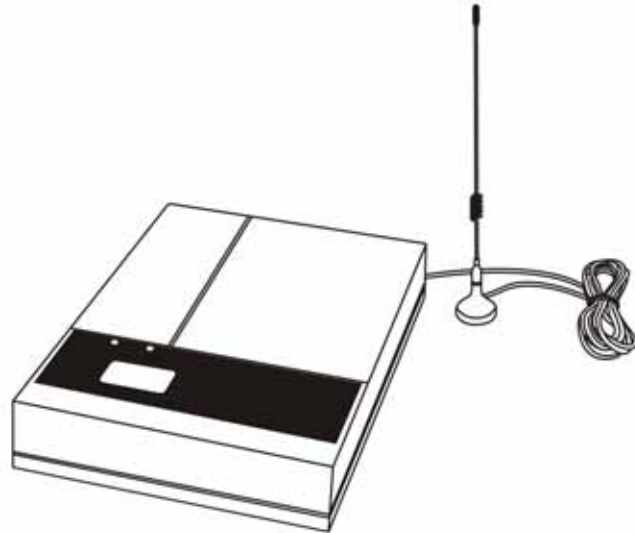

Contents

Section 1 Basic System Construction.....	1	3.9 Set Confirm Time While Dialing Out from	
1.1 Product Specification	1	CDMA(98).....	13
1.2 Packing Contents and Accessories	2	3.10 Set Economized International Long Distant Call	14
1.3 Connecting Diagram	3	3.11 Set Economized Domestic Long Distant Call	14
Section 2 Installation.....	3	3.12 Set Economized Call from CDMA Network	15
2.1 GX480 Overview Introduction.....	3	3.13 Set Other Mobile Prefix Dialing Way	15
2.2 LCD Display Status Introduction	4	Section 4 Applications	16
2.3 Main Board Installing	4	4.1 Dial Domestic Long Distant Call.....	16
2.4 Main Board Accessories Installing.....	7	4.2 Dial International Long Distant Call	17
Section 3 System Programming	10	4.3 Dial Mobile.....	17
3.1 Recover Factory Default (99)	10	4.4 Incoming Call from Line.....	17
3.2 Modify Program Setting Password (88).....	11	4.5 Incoming Call from CDMA Mobile	17
3.3 Set Call Waiting While Talking (910).....	11	4.7 Call Forwarding While Talking.....	18
3.4 Set Line Disable (910)	12	Section 5 Other Applications	19
3.5 Set DTMF Tone On Time (78).....	12	Section 6 Appendix.....	21
3.6 Set DTMF Tone Off Time (79).....	12	6.1 Usage Warnings	21
3.7 Set On HOOK Time (87).....	13	6.2 Service Guarantee	22
3.8 Set CDMA Max Dialed Out Digits (92).....	13	6.3 Contact Information	23



Section 1 Basic System Construction





1.1 Product Specification

GX480 CDMA Gateway	
Product Spec	Name: CDMA Gateway Model: GX480 Dimension: 223(L) × 1157(W) × 42(D) (mm) Weight: 495g
Network Frequency	CDMA2000 1X/800MHz
Environment Requirement	AC100 -240V Power Jack Operating Temp: 0°C - 50°C (32°F - 122°F) Operating humidity: 10% - 90% without congealment

Electrical Characteristics	Operating Power: DC6V 1.5A Operating Current: Standby < 30mA Full Load < 35mA Startup: 600mA
Packing Contents	GX480 CDMA Gateway User's Manual Quick Installing User Guide DC6V 1.5A Power Adaptor Screws for fixing device Specified Antenna RJ11 Cable

1.2 Packing Contents and Accessories

GX480 Packing Including	
GX480 Main Board	
User's Manual	
Quick Installing Guide	

Screws x 2	
Antenna	
RJ11 Cable	
AC100 - 240V 50-60Hz DC6V 1.5A Power Adaptor	

1.3 Connecting Diagram

GX480 is designed based on 3G (CDMA) for mobile phone. The major functionality is convenient for normal phone devices (telephone set, wireless phone, key phone, etc) so that dialing can go through CDMA network and receiving calls.



Section 2 Installation

2.1 GX480 Overview Introduction

Please check the GX480 each parts first before operating.

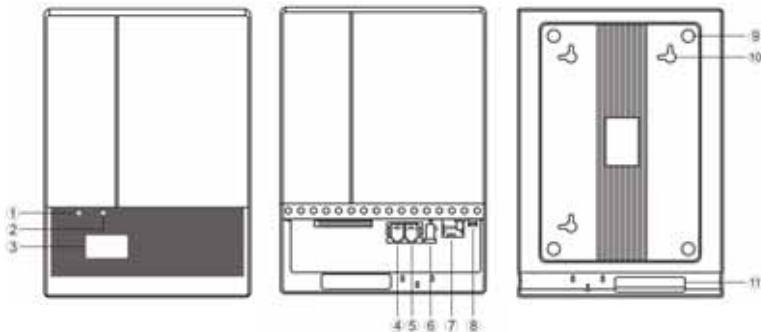

- | | |
|-------------------------------|-----------------------|
| 1. Network Status Indicator | 7. UIM Card Slot |
| 2. Telephone Status Indicator | 8. Antenna Slot |
| 3. LCD Display | 9. Cushion |
| 4. Line RJ11 Jack | 10. Suspension Hole |
| 5. Phone RJ11 Jack | 11. Cable output Hole |
| 6. DC Power Jack | |

2.2 LCD Display Status Introduction

1. Normal Standby Status Display



2. No UIM Card Status Display



3. New Inbound Call Status Display



4. Outbound Dialed No. Status Display



5. Pick Up phone (Off hook) Status Display



6. Talking Duration Counting Status Display



2.3 Main Board Installing

Cautions: Please disconnect power adaptor first;

Select appropriate screwdriver to fix the screws

Be careful to move while installing.

Accessories:

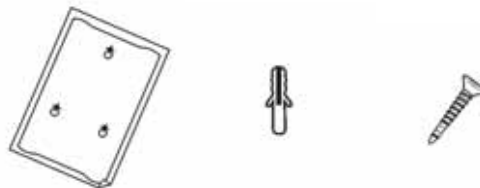

1. Take out the picture (from page 28) for fixing the main board and remove the pastern behind the picture.



3. If installing on wall will make a hole on the position specified in the picture as shown in below.

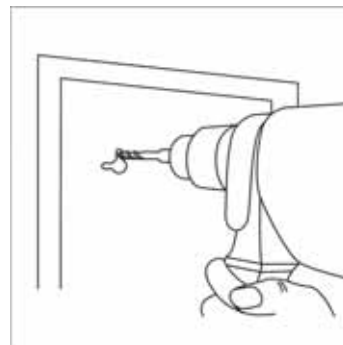

2. Put the picture in horizontal by hand to fix the position.

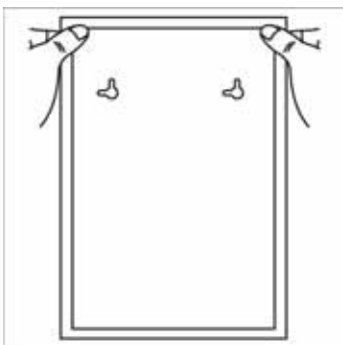

4. Take out the cushion to insert on the hole.

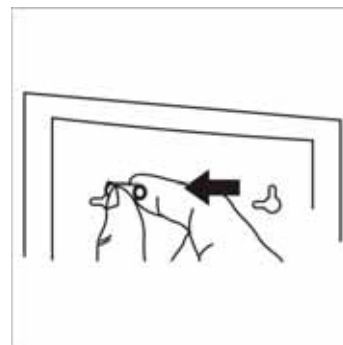

5. Insert the cushion to hole via hammer.

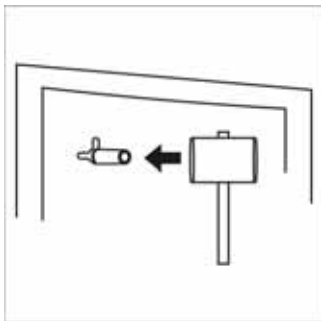

6. Take out the screws and fix them (if installing on wooden wall don't need make hole and cushion), the screws should keep 7mm in front of the wall.

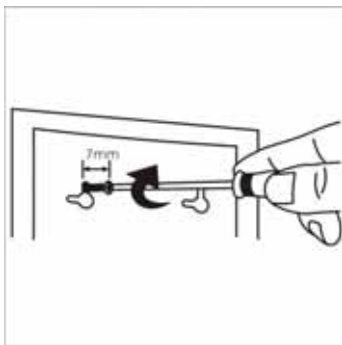

7. Remove the position picture like below.

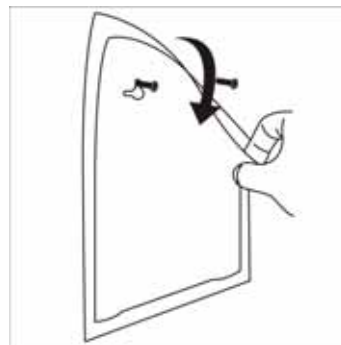

8. Install main board as per the screw's position as shown in below picture.

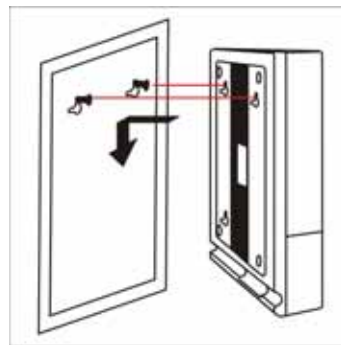

2.4 Main Board Accessories Installing

CDMA Gateway contains a special Antenna and RJ11 phone cables.

Accessories:



1. Open the cover casing as shown below, push down the cover as per the arrowhead direction.

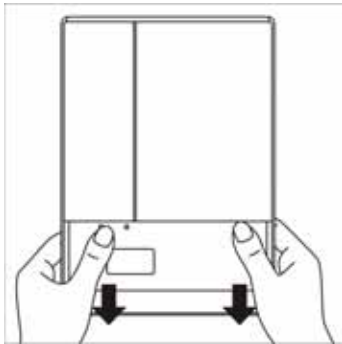

2. Install CDMA UIM mobile card, insert the UIM card as per below direction.

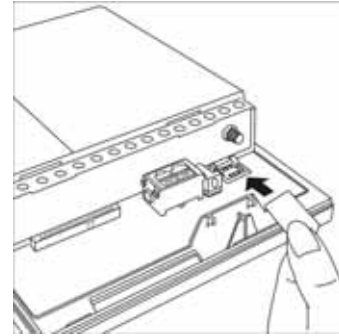

3. Install the Antenna:
 - a. Take out the specified Antenna through cable hole.

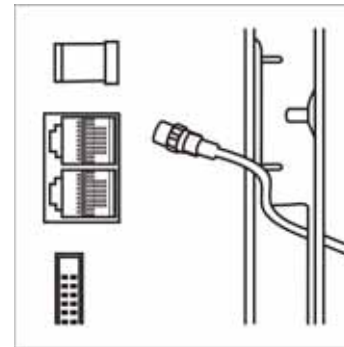

b. Screw the Antenna on the Antenna slot as per positive sequence as shown in below direction.

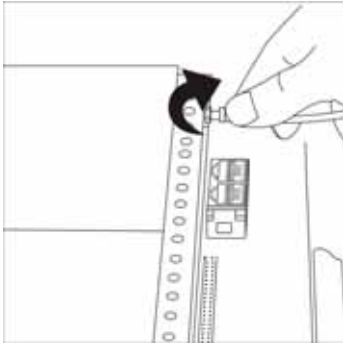

b. Connect one terminal of RJ11 cable to Phone Jack.

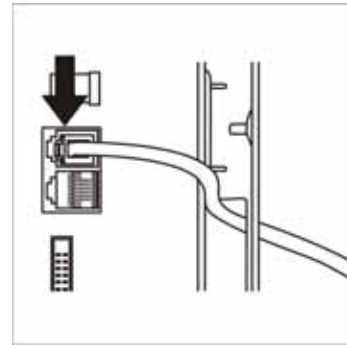

4. Install telephone set:

a. Take out the RJ11 phone cable through cable hole.

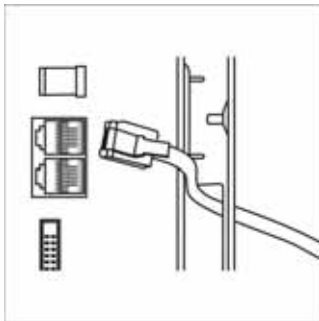

c. Connect another terminal of RJ11 cable to telephone set.

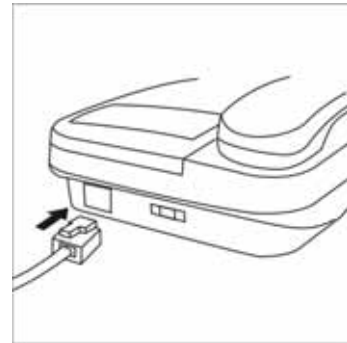

5. Install PSTN Line (C.O. Line):

a. Take out the RJ11 cable through the cable hole.

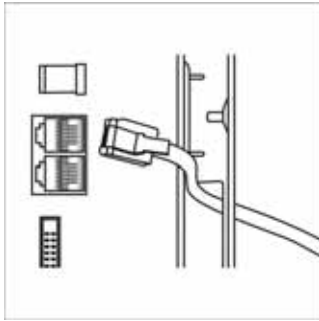

b. Connect one terminal of RJ11 Line cable to Line Jack.

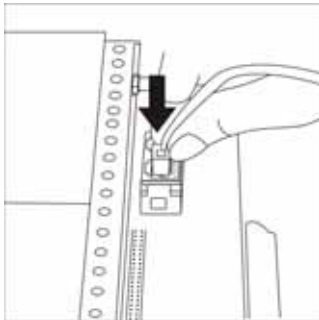

c. Connect another terminal of RJ11 Line cable to PSTN or C.O. Line socket.

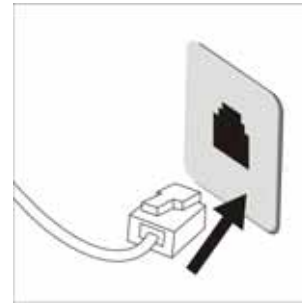

6. Install power adaptor:

Cautions: The power adaptor is special used for GX480.

Please don't use other power adaptor!

a. Take out the power adaptor from accessories (Input AC100-240V Output DC6V).



- b. Connect one terminal of DC power cable to DC Jack through the cable hole as shown in below.

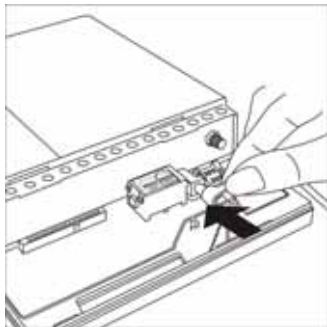

- c. Connect another terminal of DC cable to AC the wall power socket.

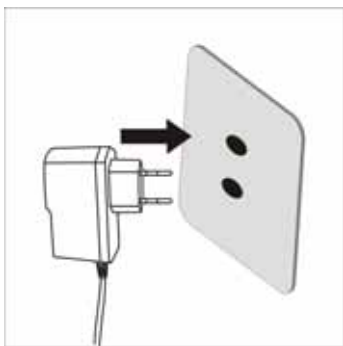

Cautions: After powered for CDMA Gateway, please notes the power indicator and LCD display status of CDMA gateway whether lights on (Normally will be lighted on status)!

Section 3 System Programming

Function Programming Procedures:

1. Pick up telephone
2. Press **# 1 #** will get [long beep]
3. Key in parameters
4. Key in setting value (if value = Null, no need enter)
5. Press *** #** will get [long beep]

Cautions: Repeat step 1 to 5 can set next functional parameters (or no need hang up phone to repeat step 3 to step 5).

3.1 Recover Factory Default (99)

☎ → # 1 # → 99 → * #



If you forgot settings during using



process, you can recover the setting to factory default, the functionalities of factory default as follows:

Call Transfer	None
Call Forward	Enable
Remote Control PW	1111
Transfer PW	None
Transfer Time Limits	None
Setting PW	None

3.2 Modify Program Setting Password (88)

 →    → 88 → (1 ~ 8 digits) →  

Once GX480 got password to modify the setting must enter password first before modifying, if forgot the password should put it back to manufacturer for decoding.

3.3 Set Call Waiting While Talking (910)

a. Disable Call Waiting:

 →    → 910 → 1 →  

This functionality is used to disable call forwarding.

b. Enable Call Waiting:

 →    → 910 → 2 →  

This functionality is used to enable call forwarding function, when the telephone is talking on Line and inbound call from CDMA simultaneously, then press FLASH button or press Hook switch on telephone can get through with CDMA incoming call, after talking to press FLASH button can recover the conversation on Line. In the same way, when the telephone is talking on CDMA and call in from Line simultaneously, using the same way can call forward to Line and recover to CDMA after talking over on Line.

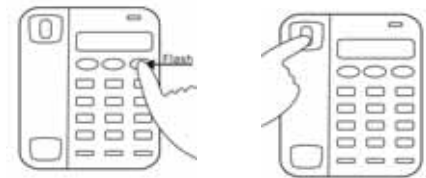

3.4 Set Line Disable (910)

 → # 1 # → 910 → 3 → * #

This functionality is used to disable Line function of GX480, when Line is not installed or not used, you can disable the Line function. When pick up phone will transfer to CDMA network automatically and call in from CDMA will not transfer to Line the telephone will be ringing directly.

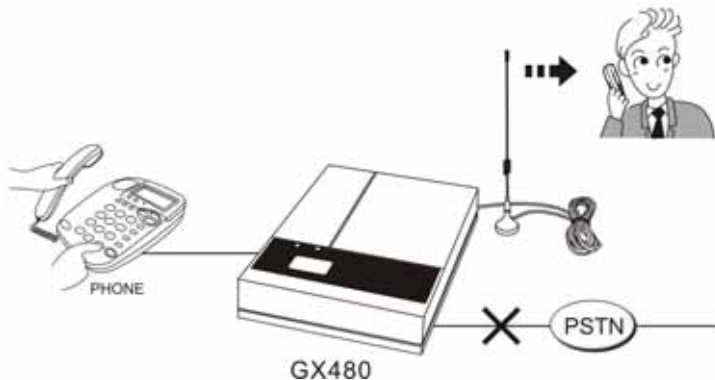

3.5 Set DTMF Tone On Time (78)

 → # 1 # → 78 → (1~2 digits) → * #

This functionality is used to set DTMF tone On time, time unit is 10ms, valid data is 2 digits, factory default is 06 (06 x 10ms = 60ms)

Cautions: In order to stable the dialing we suggest set the DTMF On time range between 05 and 10, if the telecom had enough receiving level, you can shorten the set time but keep at least 30ms will be better.

3.6 Set DTMF Tone Off Time (79)

 → # 1 # → 79 → (1~2 digits) → * #

This functionality is used to set DTMF tone Off time, time unit is 10ms, valid data is 2 digits, factory default is 06 (06 x 10ms = 60ms)

Cautions: In order to stable the dialing we suggest set the DTMF On time range between 05 and 10, if the telecom had enough receiving level, you can shorten the set time but keep at least 30ms will be better.







3.7 Set On HOOK Time (87)

 →    → 87 → (1~2 digits) →  

This functionality is used to set Hang up phone recognized time, time unit is 100ms, valid data is 2 digits, factory default is 04 (04 x 100ms = 400ms), if set value is 04 means after waiting 400ms under hang up phone, then will be recognized phone is on hook status.

Cautions: When startup call forwarding function, we suggest set this time much bigger in order to avoid noise interference.







3.8 Set CDMA Max Dialed Out Digits (92)

 →    → 92 → (1~2 digits) →  

This functionality is used to set max dialed digits from CDMA mobile terminal, valid data is 2 digits, default data is 32. Dialing from Mobile must store the dialed numbers first before dialing out together, on account of different dial speed may cause dialed no. is not completed, so the dialed interval is a must to justify whether dialed over or not, after

waiting the interval will dial out all numbers one time together (Notes: The dialing interval default is 3 seconds, please refer to '6 Mobile dialing confirm time setting' for more details. So set dialed Max digits can effectively shorten this waiting time, if the dialed no. is 10 digits, you can set the max digits to 10, once the dialed no. reach 10 digits will be dial out together immediately.

3.9 Set Confirm Time While Dialing Out from CDMA(98)

 →    → 98 → (1 digit) →  

This functionality is used to set confirm time while dialing from CDMA Mobile, time unit is 1 second, default is 3 (3 x 1sec = 3 sec), max is 9 (9 sec). The dialed codes will be stored before dialing out, after waiting this confirmed time will dial out all codes together.

For example: If set to 3 seconds means no new code dialed within 3 seconds will recognize dialing over, then will dial out the stored codes together immediately at one time.

Cautions: If you don not want to wait this confirmed time, you can dial '#' to end dialing. For example: If you want dial

phone no. is 27851234 and add '# 'on the end (27851234#), then all codes will be dialed out immediately without waiting.

3.10 Set Economized International Long Distant Call

Please make programming as per below steps.

a. Set prefix for replacing international prefix (66)

 → # 1 # → 66 → (Preset Prefix) → * #

For example: If you want to change the previous international prefix 002, please enter 002 at 'Preset Prefix' position.

b. Set prefix for changing international call prefix (01)

 → # 1 # → 01 → (Preset Prefix) → * #

For example: If you want to change international call prefix 002 to 005, please enter 005 at 'Preset Prefix' position.

c. Set Subtract Code (71)

 → # 1 # → 71 → * * * → * #

As per above a, b instructions the international prefix is 3 digits, so enter 3 '*' is a must after parameter 71.

d. Set Waiting Time for Economized Access (06)

 → # 1 # → 06 → (2 digits) → * #

This setting is used for waiting time after call transferring over, time unit is 1 second, valid data is 2 digits, factory default is 06 (06 x 1 sec = 6 sec), if you want to reduce this waiting time we suggest set it to '03'.

3.11 Set Economized Domestic Long Distant Call

Please make programming as per below steps.

a. Set Additional Prefix (02)

 → # 1 # → 02 → (Additional Prefix)
→ * #

For example: If you add additional prefix 1805 on domestic long distant call, please enter 1805 at 'Additional Prefix' position.

b. Set Additional Startup Code 67)

 → # 1 # → 07 → (Additional Startup Code)
→ * #

For example: If you want add additional startup code have 02, 03, 04, 05, 06, 07, 08, please enter 02 at 'Additional Startup Code' position.

Cautions: One time only allow 1 group startup code entered, please repeat b setting to end adding additional startup code 03, 04, 05, 06, 07, 08.

c. Set Waiting Time for Economized Access (07)

 →    → 07 → (2 digits) →  

This setting is used for waiting time after call transferring over, time unit is 1 second, valid data is 2 digits, factory default is 06 (06 x 1 sec = 6 sec), if you want to reduce this waiting time we suggest set it to '03'.

3.12 Set Economized Call from CDMA Network

Please make programming as per below steps.

a. Set Action Prefix Dialing Out from CDMA Network (68)







 →    → 68 → (Action Prefix) →  

For example: If you want to set action prefix 0980 and 0982 dialing out from CDMA network, please enter 0980 at 'Action Prefix' 0980.

Cautions: One time only allow 1 group action prefix entered, so please kindly repeat a setting to end adding action prefix

0982.

b. Set Time Counting Way While Talking (908)







 →    → 908 → (1 digit) →  

If set 908 = 1 stands time counting in increment way

If set 908 = 2 stands single time counting way

If set 908 = 3 stands no time counting way

c. Set Time for Time Counting (903)

 →    → 903 → (4 digits) →  

Valid data is 4 digits

For example: If enter 2000 stands 200.0 minutes, enter 0045 stands 4.5 minutes.

d. Disable System Code (03)

 →    → 03 →  

3.13 Set Other Mobile Prefix Dialing Way

a. Other Mobile Prefix Dialing Out from Line network

If you want to set other mobile prefix dialing out from Line network, then you do not need make other programming.

b. Other Mobile Prefix Dialing Out from CDMA network

If you want to set other mobile prefix dialing out from CDMA network, please kindly see below steps for the setting.

b.1. Set Mobile Startup Code (69)

☎️ → # 1 # → 69 → (Mobile Startup Code)

For example: If you want other mobile phone no. dialing out from CDMA, you only need set Mobile Startup Code to 09.

b.2. Set Time Counting Way While Talking (909)

☎️ → # 1 # → 909 → (1 digit) → * #

If set 909=1 stands time counting in increment way

If set 909=2 stands single time counting way

If set 909=3 stands no time counting way

b.3. Set Time for Time Counting (904)

☎️ → # 1 # → 904 → (4 digits) → * #

Valid data is 4 digits

For example: If enter 2000 stands 200.0 minutes, enter 0045 stands 4.5 minutes.

b.4. Disable System Code (04)

☎️ → # 1 # → 04 → * #

Section 4 Applications

GX480 has the feature can automatically

Select network for call transferring, the

Startup code will be automatically judged

And find out the best network for dialing out.

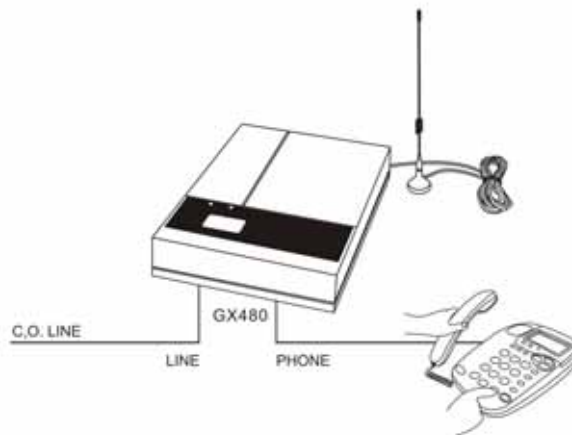

4.1 Dial Domestic Long Distant Call

When the dialed no. is started with domestic long distant

code, then it will be dialed out from Line with adding

domestic economized access number.

4.2 Dial International Long Distant Call

When the dialed no. is started with international long distant code, then it will be dialed out form Line and automatically transferred to international long distant access number.

4.3 Dial Mobile

a. Mutual Dialing Inside Network

When the dialed no. is CDMA action network, then it will be automatically selected dialing out from CDMA network.

b. Dialing Outside Network

When the dialed action phone no. is the different telecom network, then it will be dialed out as per the setting conditions from CDMA mobile or Line terminal.

b1. If using CDMA mobile dials the action phone no. in different telecom, then it will be dialed out automatically from CDMA mobile network.

b2. If using Line dials the action phone no. in different telecom, then it will be dialed out automatically from Line

terminal.

4.4 Incoming Call from Line

When Line terminal gets incoming call, the telephone will be ringing, if the user subscribed the caller ID function, then phone no. will be displayed on the telephone, pick up phone can talk with the called party, after talking to hang up phone.

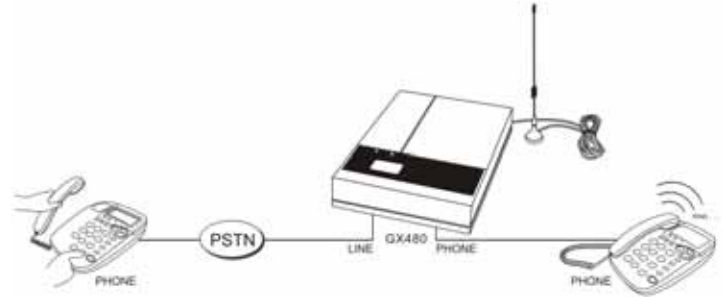

4.5 Incoming Call from CDMA Mobile

When CDMA gets incoming call, the telephone will be ringing and phone no. will be displayed on telephone if caller ID is opened by telecom, pick up phone can talk with the called

party, after talking to hang up phone.



4.6 Call Forwarding While Talking

a. Talking on Line and Inbound Call from CDMA

1. Please refer to 'all Forwarding While Talking' to enable this function.
2. When the telephone is talking on Line and CDMA call coming, then you can press FLASH button on telephone (or press Hook switch) to get through with CDMA call. After

talking to press FLASH button to recover talking on Line.



Cautions: When startup the call forwarding function, please pay attention to the On HOOK time setting, we suggest it a little bigger in order to avoid noise interference.

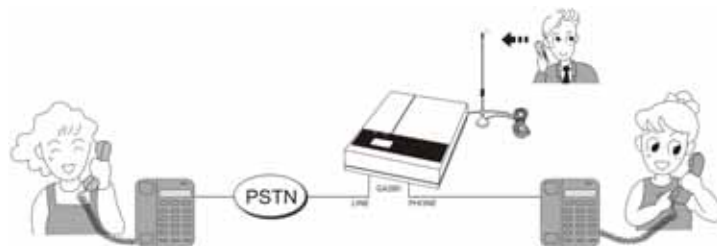

b. Talking on CDMA and Line Call Coming

1. Please refer to 'all Forwarding While Talking' to enable this function.
2. When the telephone is talking on CDMA and Line call coming, then you can press FLASH button on telephone (or

press Hook switch) to get through with Line call. After talking to press FLASH button to recover talking on CDMA.

Cautions: When startup the call forwarding function, please pay attention to the On HOOK time setting, we suggest it a little bigger in order to avoid noise interference.

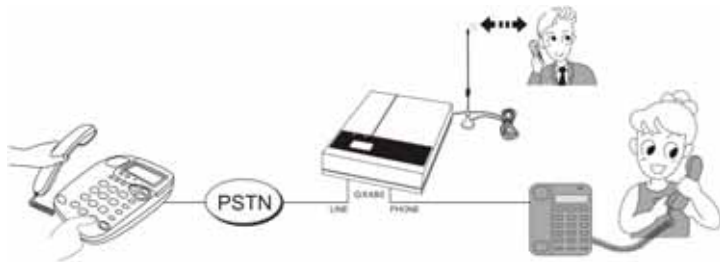

Section 5 Other Applications

1. Connect to Key phone

Install GX480 to Key phone system, then all functionalities of GX480 can share with extensions, then each extension can cancel line (GX480 installed the Line) to dial CDMA and economized network.

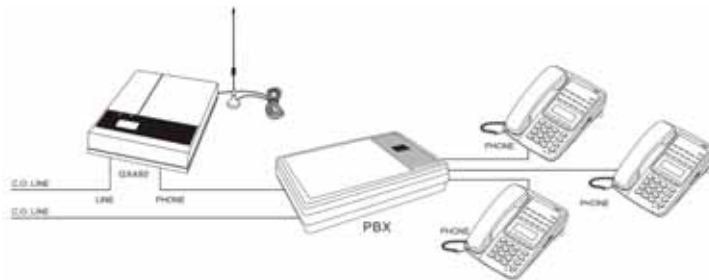

2. Connect to VoIP

Connect GX480 LINE terminal to FXS port of VOIP, then the functionality of GX480 can share to remote users. In this way, not only dial CDMA network can mutual dialing to economize charge, but also the remote user of VOIP dial the international call will be much cheaper.

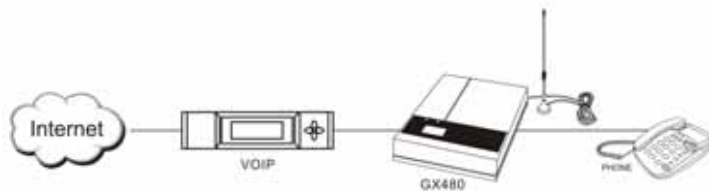

3. Connect to internal line of Key phone

Install GX480 to internal line of extension under key phone system can realize below functions.

a. Dial Ext. directly while CDMA call coming.

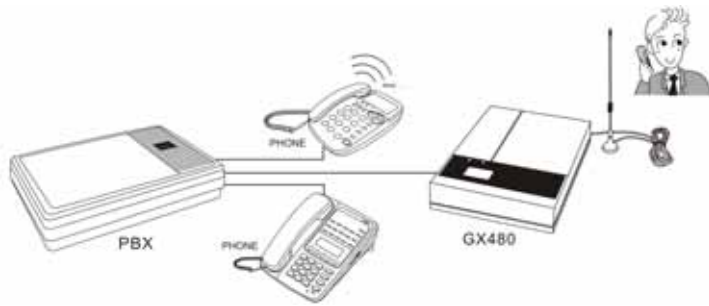

b. Other Ext. can transfer to CDMA mobile.

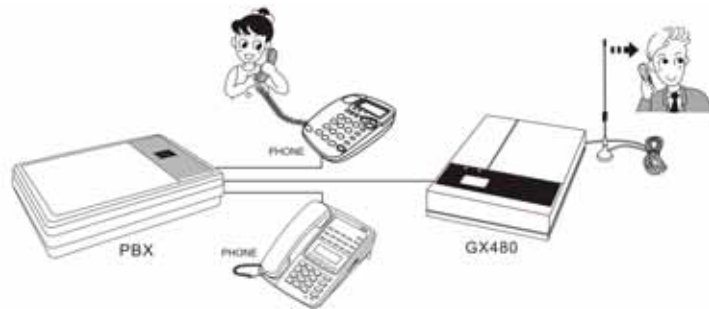

c. Make phone call by key phone line via CDMA call.



4. Connect to Billing Telephone

If no normal line network can disable GX480 Line, then connect billing telephone to phone port of GX480, in this way will facilitate more user to dial CDMA network and can billing via inserting coin.

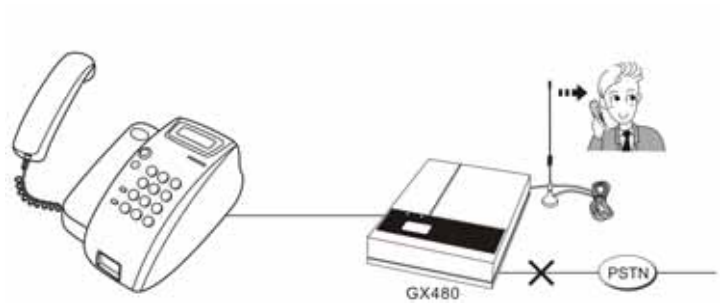

5. Set Line Disable Call Only through CDMA



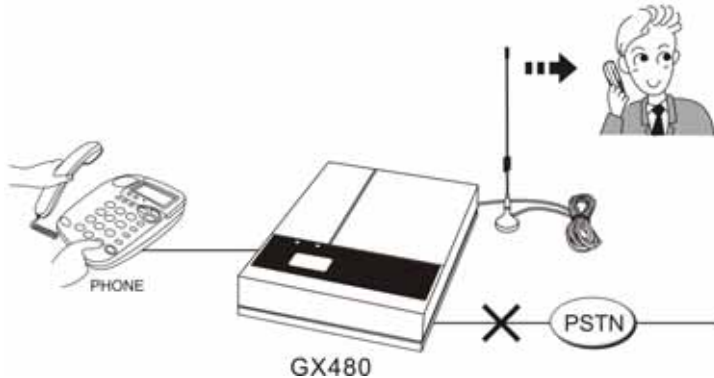

If you only want to dial CDMA mobile network, you can disable GX480 Line function, then pick up phone, the dialed call will only go through CDMA network to dial out.



Section 6 Appendix

6.1 Usage Warnings

Operational Warning and Notice

	1. Place product away from dusty or massed area. The dust often affects and result product shortness.
	2. Get away from any magnetic area (e.g. Speaker or TV) to prevent magnetic interference.
	3. Do not place the product under the sunlight.
	4. Do not place the product under temperature of 0C or 30F; or over temperature of 50C or 122F. These temperatures will affect the switch and will not be able to operate normally.



5. Prevent from getting liquid, water or under vapory environment.



6. Turn off your product before you do cleaning. Clean without any liquidized oil or cleaner.

7. Do not open the switch at any circumstances. Unauthorized open or disassemble the product will occur failure of machine operation and your product's warranty will be terminated.

8. Maintain the product under a dry environment. Any vapory or liquids will shorten the circuits inside switch.

9. If you are experiencing the following situation(s), please turn off the power and contact our Repair Center immediately:

- Impair of power cables
- Has liquid emerge
- Breakage of case due to accident dropping

6.2 Service Guarantee

Product Warranty

This product has made a series of quality control tests and exams by Artech, Ltd., Taiwan (refers to AT). If by a normal circumstances the product is defeated without users' failure of operation or breakage, the product is covered by its warranty and will be repaired by AT.

Warranty Terms:

1. Hardware failure: The product is covered by the full-warranty (free charge of repair) without user's failure of operation or breakage.
2. Software: Application program and CD driver will be provided from us, if you install any others program, it will not belong to servicing range.
3. Others:
 - A. All of included accessories, user's guide, cables, and CD/software is NOT under warranty and will not replace at all.
 - B. All warranties are covered in world-wide. Please

refers to World-wide Warranty and its terms at
<http://www.artech.com.tw>

Details of Warranty

This product is covered by one year warranty from the date you purchased. If in a normal circumstance without user's failure of operation or breakage, the product will be covered in full-warranty. If in any other circumstances list in the following, a repair fee will apply to you:

1. if the defeated product is caused by a natural calamity or power outage/pressure
2. if the defeated product is caused by unauthorized open/disassemble or change of circuit specification from other resources than Artech
3. accidental dropping by users' act of moving or displacing the product
4. if the defeated product is caused by use the product for other purpose other than it was original design

6.3 Contact Information

ARTECH Technology Design Co., Ltd.

Address: 3F, NO. 8, Lane 263, Chong Yang Road, Nankang Dist., Taipei, Taiwan

Tel.: 886-2-2785-2954

Fax: 886-2-2786-2783

E-mail: sales@artech.com.tw

Service Time: Monday to Friday (AM 9:00 ~ PM: 6:00)

Website: www.artech.com.tw

